



# Disinfection Mats

4591818



4597036



4593424



Entrance Disinfection Mats are designed to be placed at the entrance to dairy barns, hog enclosures, poultry houses and vegetable, fruit and grain storage facilities, to disinfect the boots and shoes of workers as they enter. Mats are made with tough poly mesh over a foam core with non-permeable bottom and sides to contain the disinfectant solution.

When filled, the Mats repel dirt and stay effective for approximately one week when they should be lifted, rinsed and left to hang-dry overnight. Mat must be used on level surface.

**4591818** Small Disinfection Mat, 18" by 18" by 1" deep, holds approx. 3/4 gallon.  
Wt. 1.35 lbs. (unfilled).

**4593424** Disinfection Mat, 34" by 24" by 1" deep, holds approx. 2 gallons. Wt. 5 lbs. (unfilled).

**4597036** Heavy Duty Disinfection Mat, 70" by 36" by 1.5" deep, holds approx. 9 gallons.  
Wt. 17 lbs. (unfilled).

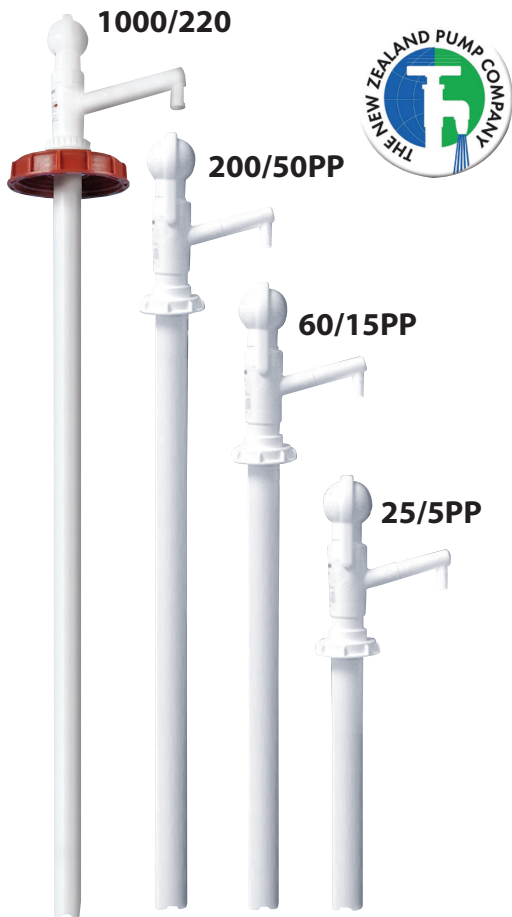

# Ezi-action® Safety Drum Pump

Ezi-Action Safety Drum Pump provides superior design and safety features in four sizes from 5-gallon pails to IBC Totes. Smooth pump action delivers approximately 15 oz. per stroke on both the up and down stroke for continuous action. The polypropylene material is resistant to a range of acidic, caustic and chlorine-based chemicals. FDA approved.

Ezi-Action Pumps are designed with safety features to avoid user contact with chemical. A lock strap prevents accidental pumping and the spout is long enough to accept a hose and clamp for bottom filling of containers. Pumps include adapters for most commonly-used containers. Pumps are vented through the connectors and safety cap adapter. Optional Safety Measure Jug with Adapter is available separately for direct filling into the jug. 24 oz. Jug is calibrated for ounces and mLs.

Pumps are provided with a white lock strap to prevent accidental pumping. Optional colored straps are available for color-coding or for color contrast.

- |                 |   |
|-----------------|---|
| <b>1000/220</b> | Pump for IBC Tote. Wt. 3 lbs.                   |
| <b>200/50PP</b> | Pump for 55-Gallon Drum. Wt. 3 lbs.             |
| <b>60/15PP</b>  | Pump for 15-Gallon Drum. Wt. 2 lbs.             |
| <b>25/5PP</b>   | Pump for 5-Gallon Pail. Wt. 1 lb. Service Parts |

## Floating Gong Brush



**1030-084** 20" Gong, yellow polypropylene bristles, tan floating block.

## Chemical-Resistant Glove



Nitri-Solve Waterproof Glove is made of 15 mil nitrile with flock lining. A good choice when handling harsh cleaners, petrochemicals, oils and greases. Specify small, medium, large or extra large by add S, M, L or XL after the stock number.

**A730\*** Pair of Flock-Lined Nitri-Solve Gloves

## Stainless Steel Pails



Pail with  
Tilting  
Handle

Plain Pail  
Cover sold  
separately

A long-time favorite, our Stainless Steel Pails are heavy one-piece seamless construction throughout. Made of 18-8 Type 304 stainless steel, the seamless construction assures greater tensile strength. With mirror polish outside surface and satin finish inside, our Pails are easily cleaned to the most exacting standards.

- |             |                               |          |
|-------------|-------------------------------|----------|
| <b>1009</b> | Plain Pail, 9 qt.             | 3.25 lb. |
| <b>1013</b> | Plain Pail, 13 qt.            | 4.5 lb.  |
| <b>1113</b> | Pail with Tilt Handle, 13 qt. | 5 lb.    |
| <b>1016</b> | Plain Pail, 16 qt.            | 5 lb.    |
| <b>1116</b> | Pail with Tilt Handle, 16 qt. | 5.5 lb.  |
| <b>1020</b> | Plain Pail, 20 qt.            | 7.5 lb.  |
| <b>1120</b> | Pail with Tilt Handle, 20 qt. | 9 lb.    |



The Coburn Company, Inc. • P O Box 147 • Whitewater, WI 53190 U.S.A.

800 776 7042

262 473 2822

coburn.com

info@coburn.com